

NO OIL ON SURFACE AFTER
CHROMIC ANODIZING
"FOR BONDING"

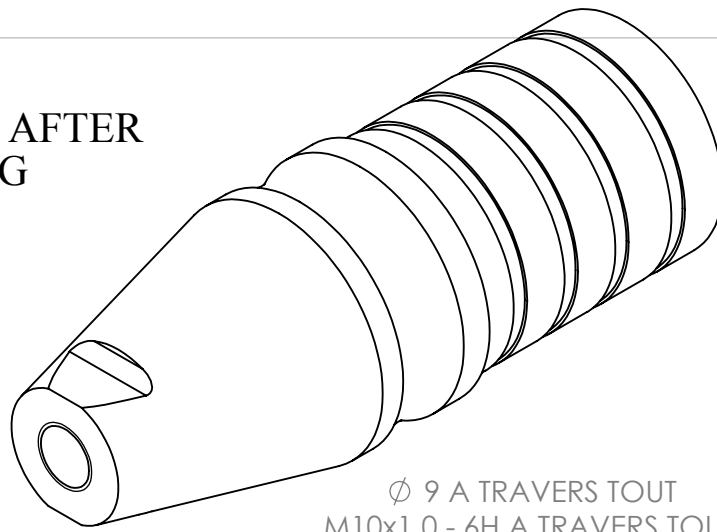

Ø 9 A TRAVERS TOUT
M10x1.0 - 6H A TRAVERS TOUT

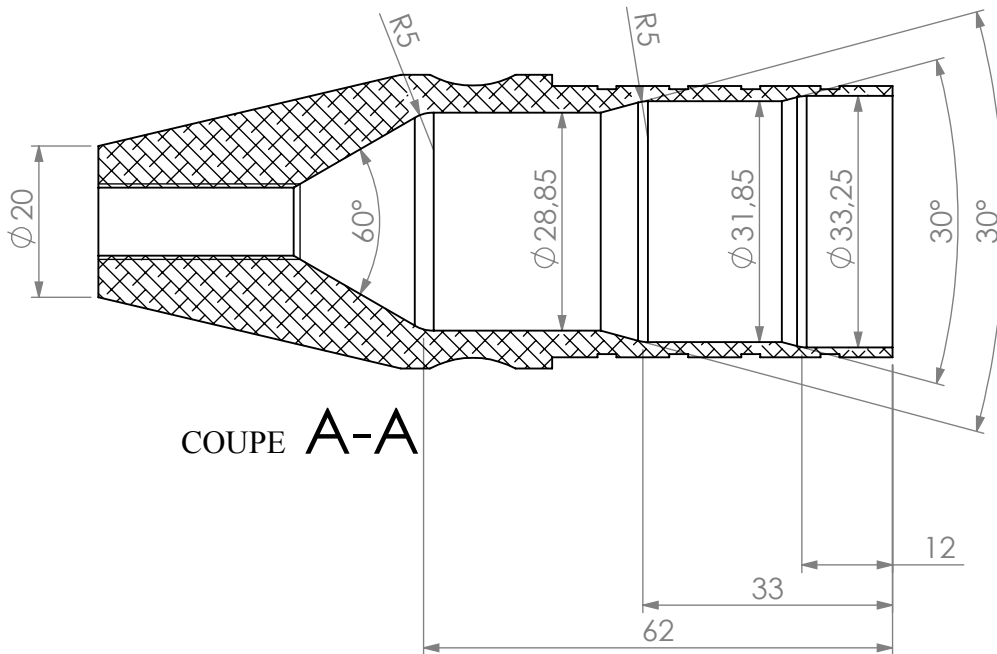
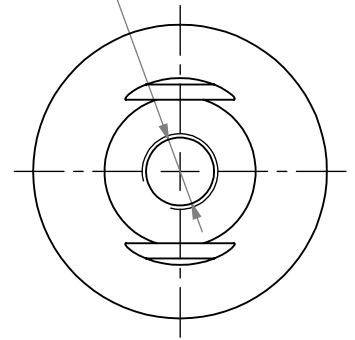
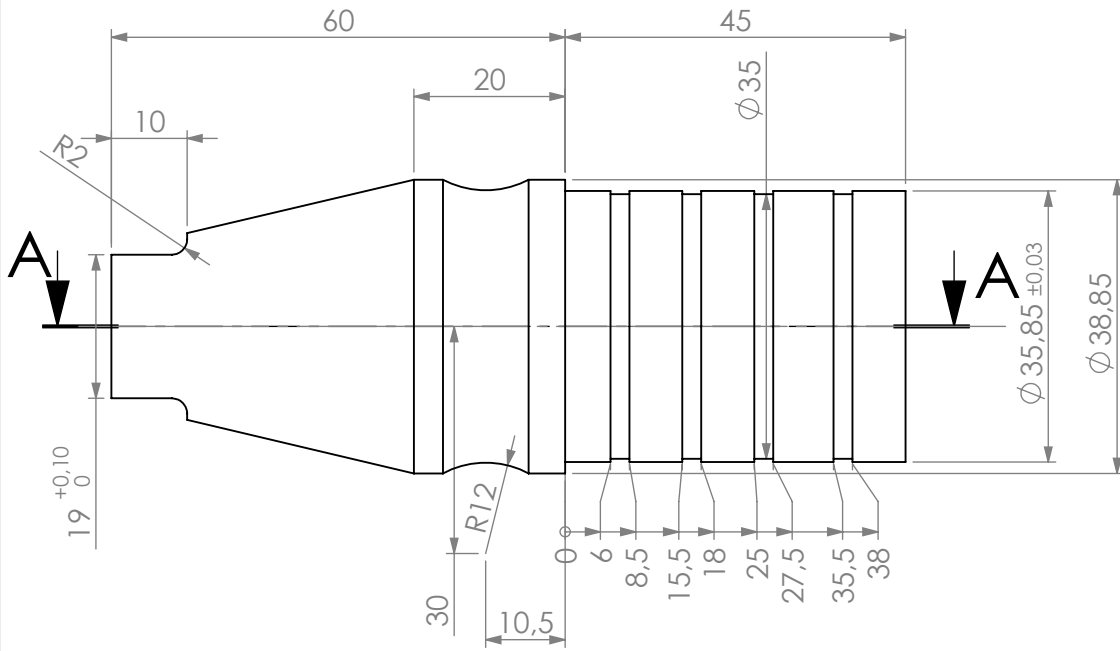

7075 Material only
Chromic anodized
careful : threading M10 pitch 1

March 02/2015

Origine drawing

SC 0

MAGIC 200

Ech: 1:1

Format: A4

Material: 7075

Qty: 1



Weight in gr: 116.86

Tol générale:
±0.2

Heat Treatment: -

N°

DESIGNATION

Surface Treatment: Chromic anodized

Embout bielle carb 36x39